

Write your name here

Surname

Other names

**In the style of:
Pearson Edexcel
GCSE**

Centre Number

--	--	--	--	--

Candidate Number

--	--	--	--	--

Mathematics

A* type questions

Higher Tier

GCSE style questions arranged by topic

Paper Reference

1MA0/2H

You must have: Ruler graduated in centimetres and millimetres, protractor, pair of compasses, pen, HB pencil, eraser, calculator.

Total Marks

Instructions

- Use **black** ink or ball-point pen.
- **Fill in the boxes** at the top of this page with your name, centre number and candidate number.
- Answer **all** questions.
- Answer the questions in the spaces provided – *there may be more space than you need.*
- **Calculators may be used.**
- If your calculator does not have a π button, take the value of π to be 3.142 unless the question instructs otherwise.
- Diagrams are **NOT** accurately drawn, unless otherwise indicated.
- You must **show all your working out.**



Information

- The total mark for this paper is 80
- The marks for **each** question are shown in brackets – *use this as a guide as to how much time to spend on each question.*

Advice

- Read each question carefully before you start to answer it.
- Keep an eye on the time.
- Try to answer every question.
- Check your answers if you have time at the end.

Turn over ►



- 1 258 Year 9 were choosing the subjects they would be taking in Year 10. The table shows information about these students.

	Subject to be studied		
	Geography	History	Spanish
Male	45	52	26
Female	25	48	62

A sample, stratified by the subject studied and by gender, of 50 of the 258 students is taken.

- (a) Work out the number of male students studying Spanish in the sample.

.....
(2)

- (b) Work out the number of female students in the sample.

.....
(2)

(Total for Question 1 is 4 marks)

-
- 2 Prove that $(3x + 1)^2 - (3x - 1)^2$ is a multiple of 4, for all positive integer values of x .

(Total for Question 2 is 3 marks)



3

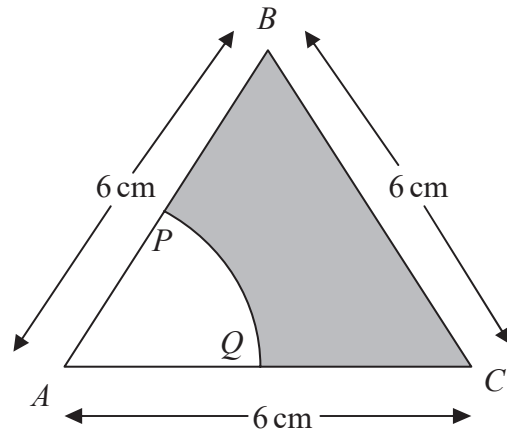

Diagram **NOT**
accurately drawn

The diagram shows an equilateral triangle ABC with sides of length 6 cm.

P is the midpoint of AB .

Q is the midpoint of AC .

APQ is a sector of a circle, centre A .

Calculate the area of the shaded region.

Give your answer correct to 3 significant figures.

..... cm^2

(Total for Question 3 is 4 marks)



4 Make A the subject of the formula

$$x = \sqrt{\frac{A}{3}}$$

$$A = \dots\dots\dots$$

(Total for Question 4 is 2 marks)

5 (a) Write 12 500 in standard form.

.....
(1)

(b) Write 2.48×10^{-3} as an ordinary number.

.....
(1)

(c) Work out the value of

$$23\,500 \div (1.25 \times 10^{-4})$$

Give your answer in standard form.

.....
(2)

(Total for Question 5 is 4 marks)



- 6 **X** and **Y** are two solid shapes which are mathematically similar.
The shapes are made from the same material.

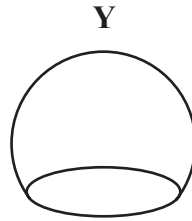
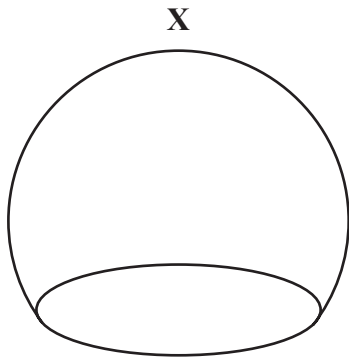

Diagram **NOT**
accurately drawn

The surface area of **X** is 50 cm^2 .

The surface area of **Y** is 18 cm^2 .

The mass of **X** is 500 grams.

Calculate the mass of **Y**.

..... grams

(Total for Question 6 is 4 marks)



7 The diagram shows a sector of a circle with centre O .
The radius of the circle is 8 cm.

XYZ is an arc of the circle.

XZ is a chord of the circle.

Angle $XOZ = 40^\circ$

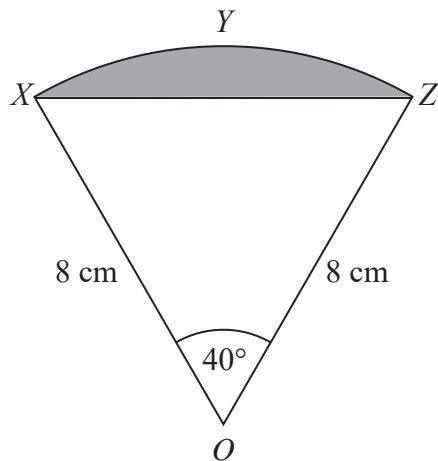

Diagram **NOT**
accurately drawn

Calculate the area of the shaded segment.
Give your answer correct to 3 significant figures.

..... cm²

(Total for Question 7 is 5 marks)



- 8 The table shows six expressions.
 x is a positive integer.

$2x - 3$	$3x - 2$	$3(x + 4)$	$4x + 1$	$4(3x + 1)$	$2x + 1$
----------	----------	------------	----------	-------------	----------

(a) From the table, write the expression whose value is

(i) always even

.....

(ii) always a multiple of 3

.....

(2)

(b) From the table, write the expression which is a factor of $4x^2 - 1$

.....

(1)

(Total for Question 8 is 3 marks)

9 (a) $n > -3$

Show this inequality on the number line.

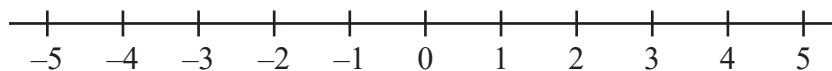

(2)

(b) Solve the inequality $7x + 36 \leq 8$

.....

(2)



10 In a sale the normal price of a pen is reduced by 10%.

The sale price of the pen is £4.86

Calculate the normal price of the pen.

£.....

(Total for Question 10 is 3 marks)



11 The diagram shows two similar triangles.

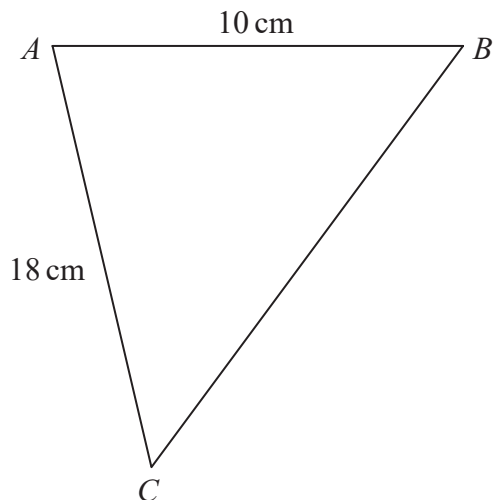
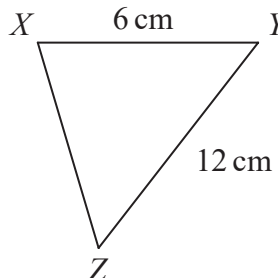

Diagram **NOT** accurately drawn



In triangle ABC , $AB = 10$ cm and $AC = 18$ cm.
In triangle XYZ , $XY = 6$ cm and $YZ = 12$ cm.

Angle $ABC =$ angle XYZ .
Angle $CAB =$ angle ZXY .

(a) Calculate the length of BC .

..... cm
(2)

(b) Calculate the length of XZ .

..... cm
(2)

(Total for Question 11 is 4 marks)



- 12** The surface area of Venus is 510 072 000 km².
The surface area of Jupiter is 6.21795×10^{10} km².
The surface area of Jupiter is greater than the surface area of Venus.
How many times greater?
Give your answer in standard form.

(Total for Question 12 is 5 marks)



13 The table shows some expressions.

w , x , y and z represent lengths.

π and 2 are numbers that have no dimensions.

$y^2(x + z)$	$\pi w^2 y^2$	$\frac{w^3 x}{y^3}$	$\pi w^2 x$	$\frac{2w^3 z}{y}$	z^2	$2w + x^2$

Tick (✓) the boxes underneath the **three** expressions which could represent volumes.

(Total for Question 13 is 3 marks)



- 14** There are three big employment sites in Knutsford.
The table shows the number of employees in each of these sites.

Barclays	Longridge	Parkgate
750	700	900

Georgina takes a sample of 50 employees stratified by site. Work out the number of employees from Longridge in the sample.

.....

(Total for Question 14 is 2 marks)



15 (a) On the number line below, show the inequality $-2 < x < 3$

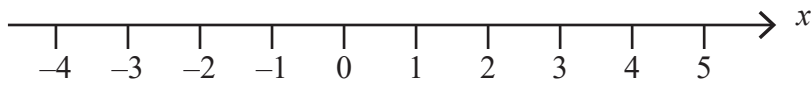

(1)

(b) Here is an inequality, in y , shown on a number line.

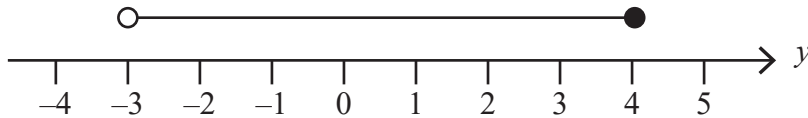

Write down the inequality.

.....

(2)

(c) Solve the inequality $4t - 5 > 9$

.....

(2)

(Total for Question 15 is 5 marks)



16

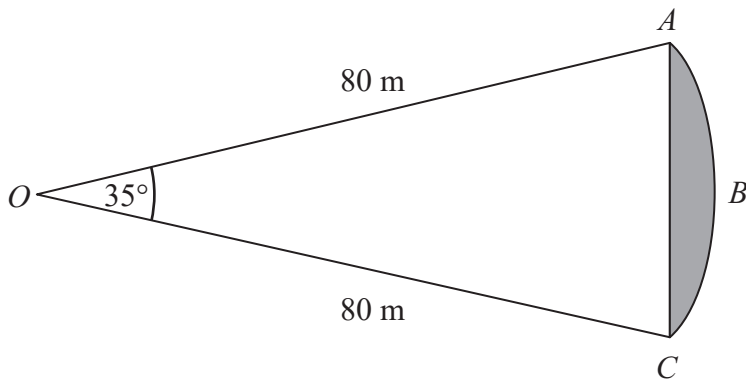

Diagram **NOT**
accurately drawn

ABC is an arc of a circle centre O with radius 80 m .
 AC is a chord of the circle.
Angle $AOC = 35^\circ$.

Calculate the area of the shaded region.
Give your answer correct to 3 significant figures.

..... m^2

(Total for Question 16 is 5 marks)



17 The table below gives some information about some students in a school.

Year group	Boys	Girls	Total
Year 12	126	94	220
Year 13	77	85	162
Total	203	179	382

Andrew is going to carry out a survey of these students.
He uses a sample of 50 students, stratified by year group and gender.

Work out the number of Year 13 girls that should be in his sample.

.....
(Total for Question 17 is 2 marks)

18 y is directly proportional to x .

When $x = 500$, $y = 10$

(a) Find a formula for y in terms of x .

$y = \dots\dots\dots$
(3)

(b) Calculate the value of y when $x = 350$

$y = \dots\dots\dots$
(1)

(Total for Question 18 is 4 marks)



19 A and B are vertices of a cuboid.

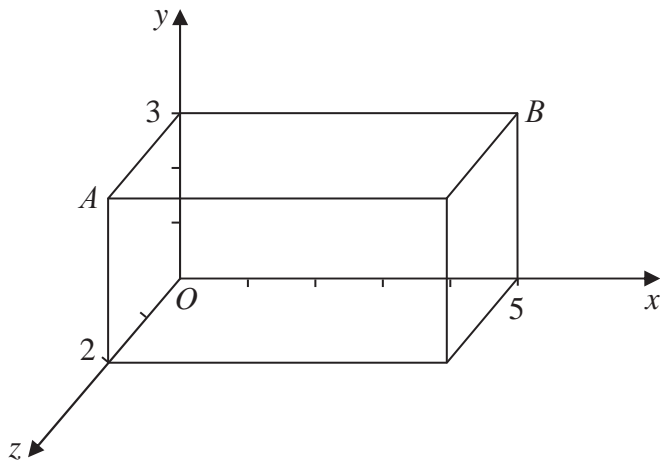

Diagram NOT accurately drawn

(a) Write down the coordinates of point A .

(..... , ,)
(1)

(b) Write down the coordinates of point B .

(..... , ,)
(1)

(Total for Question 19 is 2 marks)

20 (a) Write 83 500 000 in standard form.

.....
(1)

(b) Work out $(5.2 \times 10^{-7}) \times (2.8 \times 10^{-9})$

Give your answer in standard form.

.....
(2)

(Total for Question 20 is 3 marks)

